

VISUALIZING SI UNITS

ENERGY (E, W)

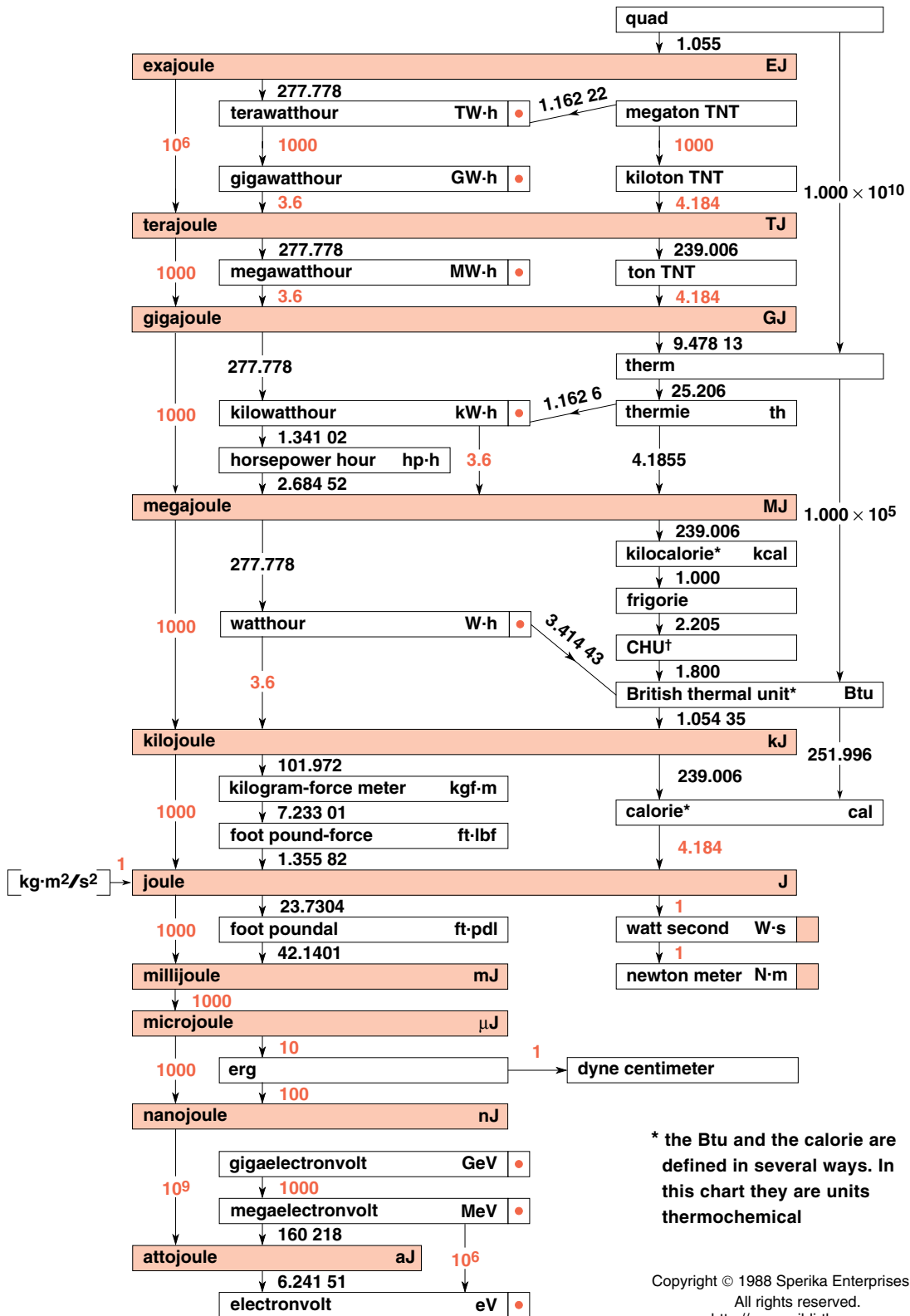

† CHU (°C Heat Unit) is the heat required to raise the temperature of 1 lb of water 1°C